

**NFINITY**

**SOFTEC**

# OUR VISION



From ID OCR and  
Identity verification ...



... to digital native experiences  
and digital contracting.

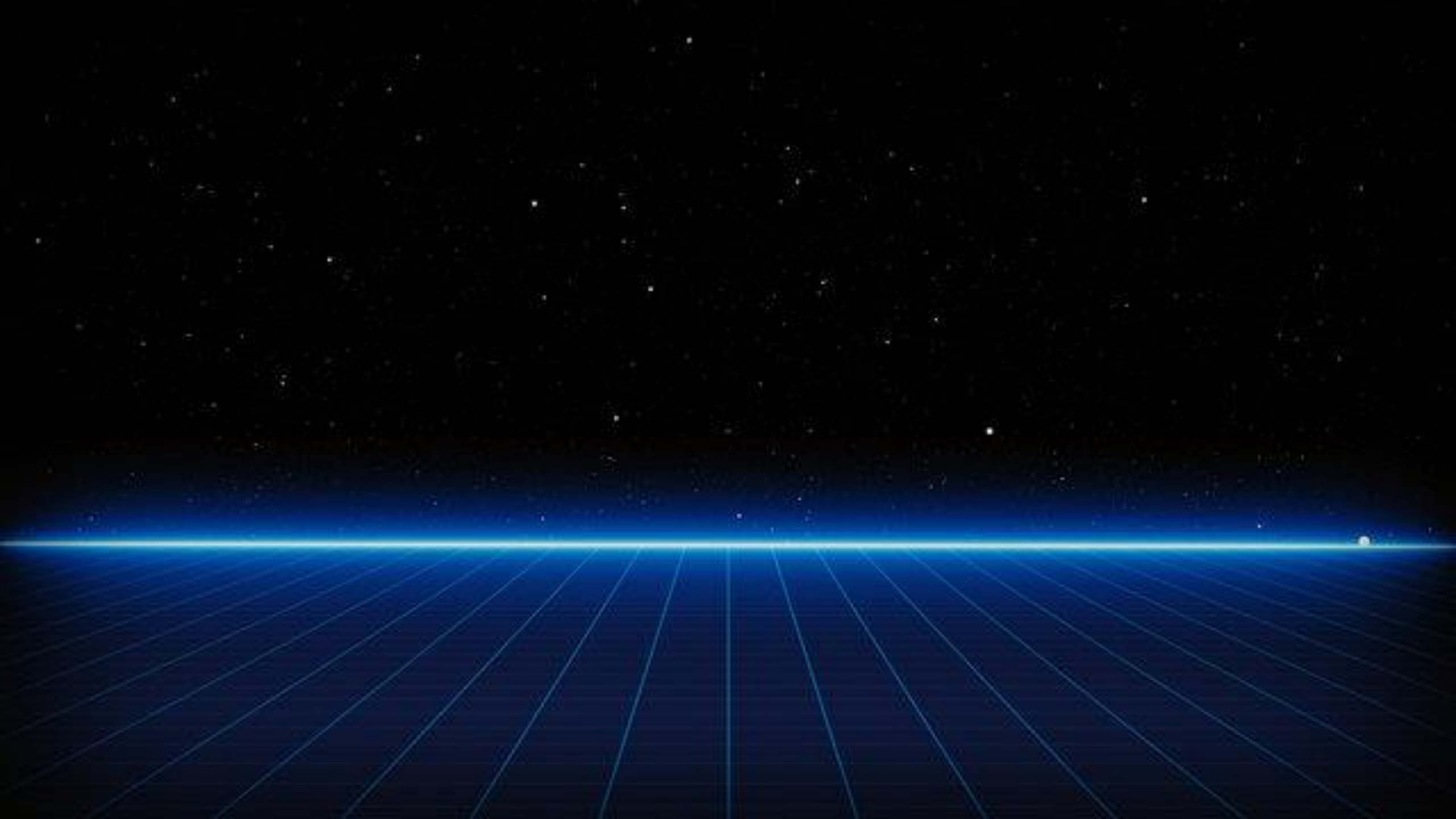

# DIGITAL IDENTITY VERIFICATION PROCESS



Instructions

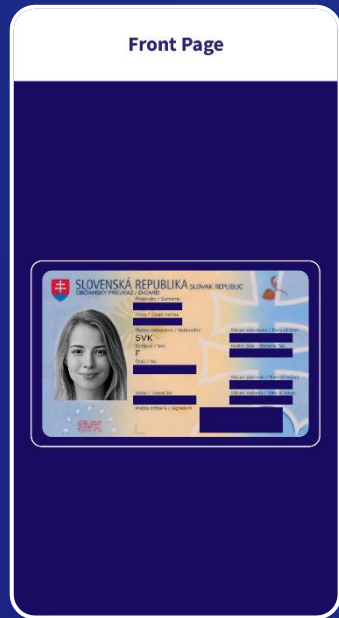

ID(s) capture  
(front and rear  
pages)



Antifraud and  
Data review

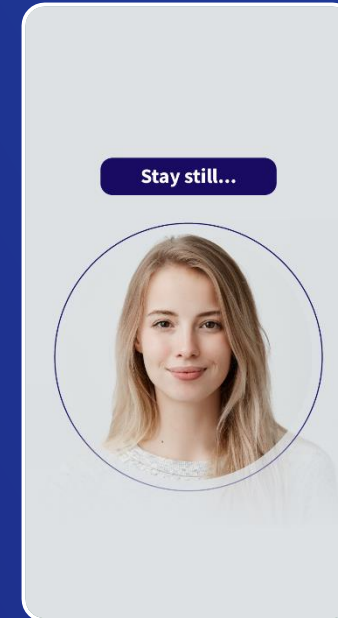

Selfie capture &  
Passive/active  
liveness check



Identity verified

# Value delivered - SaaS

- Prototyping / frontend iterations from Day 1
- Operations
- Scalability at will (and automated)
- Up to date software / security

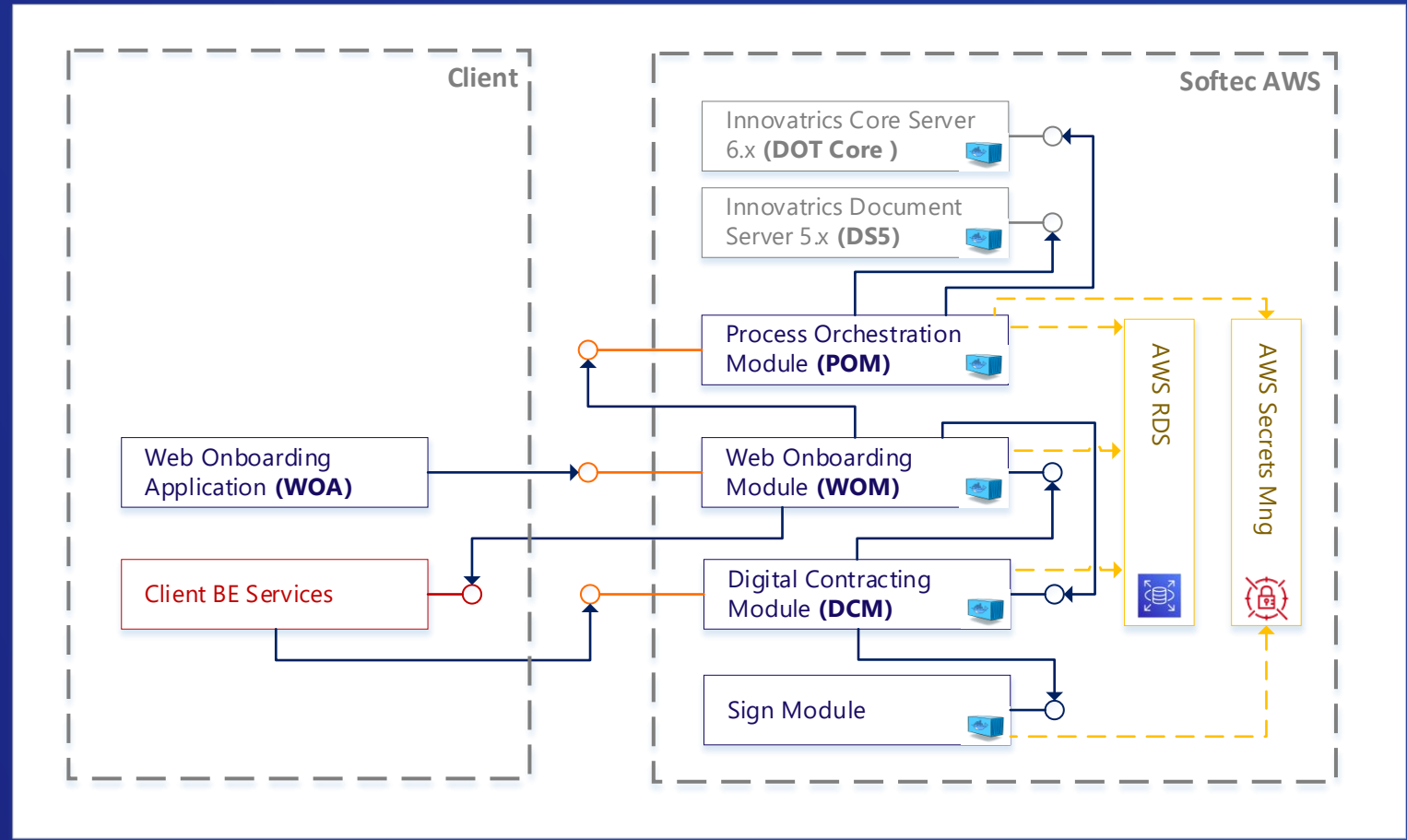

# Value delivered – Funnel tracking & Analysis



txnCount # 1003  
uniqueClientCnt # 789

first transaction started: 24.05.2021 00:05:28  
last transaction started: 31.05.2021 21:29:42  
last transaction end: 31.05.2021 22:30:27



Omnichannel  
use

Continuous improvement  
(Data driven)

Customer Migration  
(Self / Assisted)

Group wide utilization